

4000 series O-ring tub for the *Wolfspeed*™ XM3 module with MDT pin fin baseplate.

The **4012D O-ring tub** is a **double-sided aluminum friction stir welded** tub for direct cooling of the Wolfspeed XAB525M12XM3.

Flow paths have been optimized specifically for the high heat flux of silicon carbide. The combination of this tub and the XAB module with **MDT (micro deformation technology)** baseplate allows for very low thermal resistance, low pressure drop and balanced parallel flow.

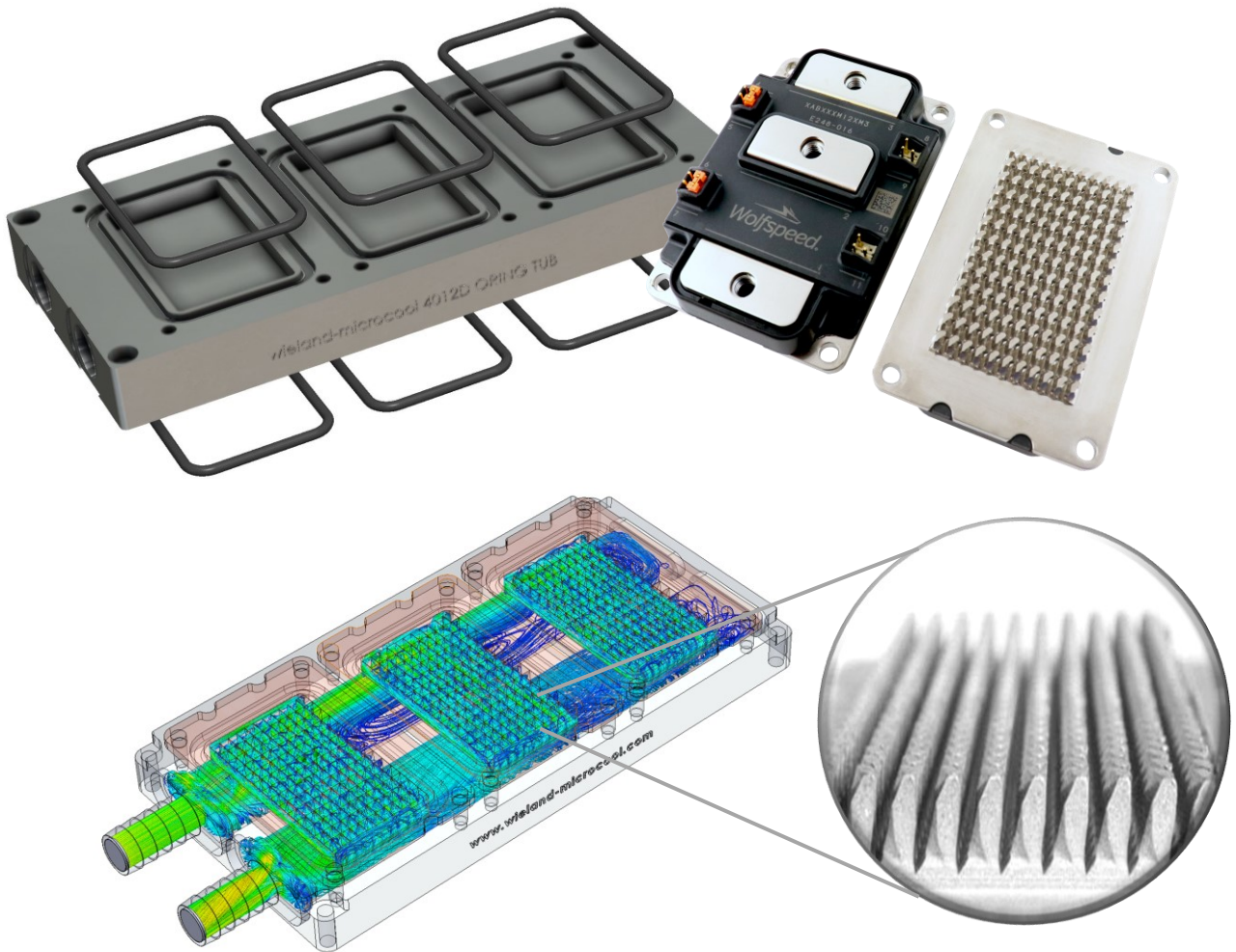

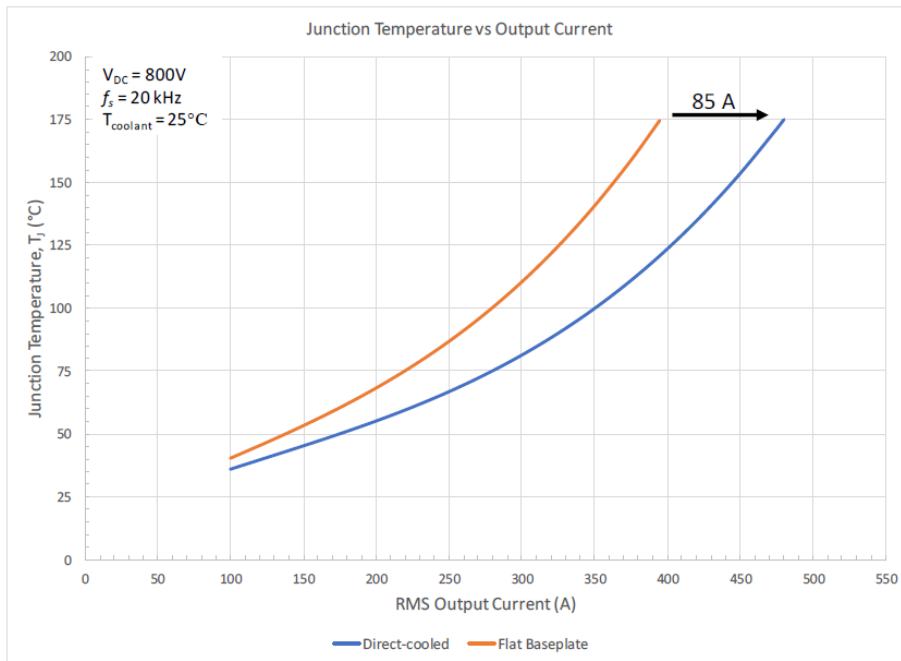
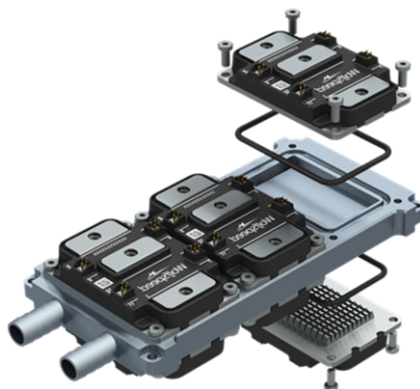

Fig. 9. Junction temperature vs. three-phase output current for direct-cooled and flat baseplate XM3 modules operating in an XM3 three-phase inverter reference design running off an 800-V dc bus and switching at 20 kHz.

Using a 50/50 water-ethylene-glycol coolant with a flowrate of 12 L/min and a temperature of 25°C, the maximum power dissipation for the flat baseplate CAB450M12XM3 is measured at 750 W per position at a junction temperature of 175°C for a thermal resistance of 0.2°C/W for $R_{\theta JL}$. For the same coolant conditions, the direct-cooled XAB525M12XM3 has a maximum power dissipation of 1070 W at a junction temperature of 175°C for a thermal resistance of 0.14°C/W for $R_{\theta JL}$.

We can see from these results that while the 0.13°C/W $R_{\theta JC}$ specified for the CAB450M12XM3 is lower than the $R_{\theta JL}$ of the XAB525M12XM3, when you factor in the thermal resistance of the TIM and cold plate, the actual $R_{\theta JL}$ for the flat baseplate module is 43% higher than the direct-cooled module. For the designer this means that using the direct-cooled solution leads to a lower junction temperature for the same power level, resulting in better reliability. Alternatively, the output power can be increased with the additional thermal overhead.

http://www.how2power.com/newsletters/2010/articles/H2PToday2010_design_Wolfspeed.pdf



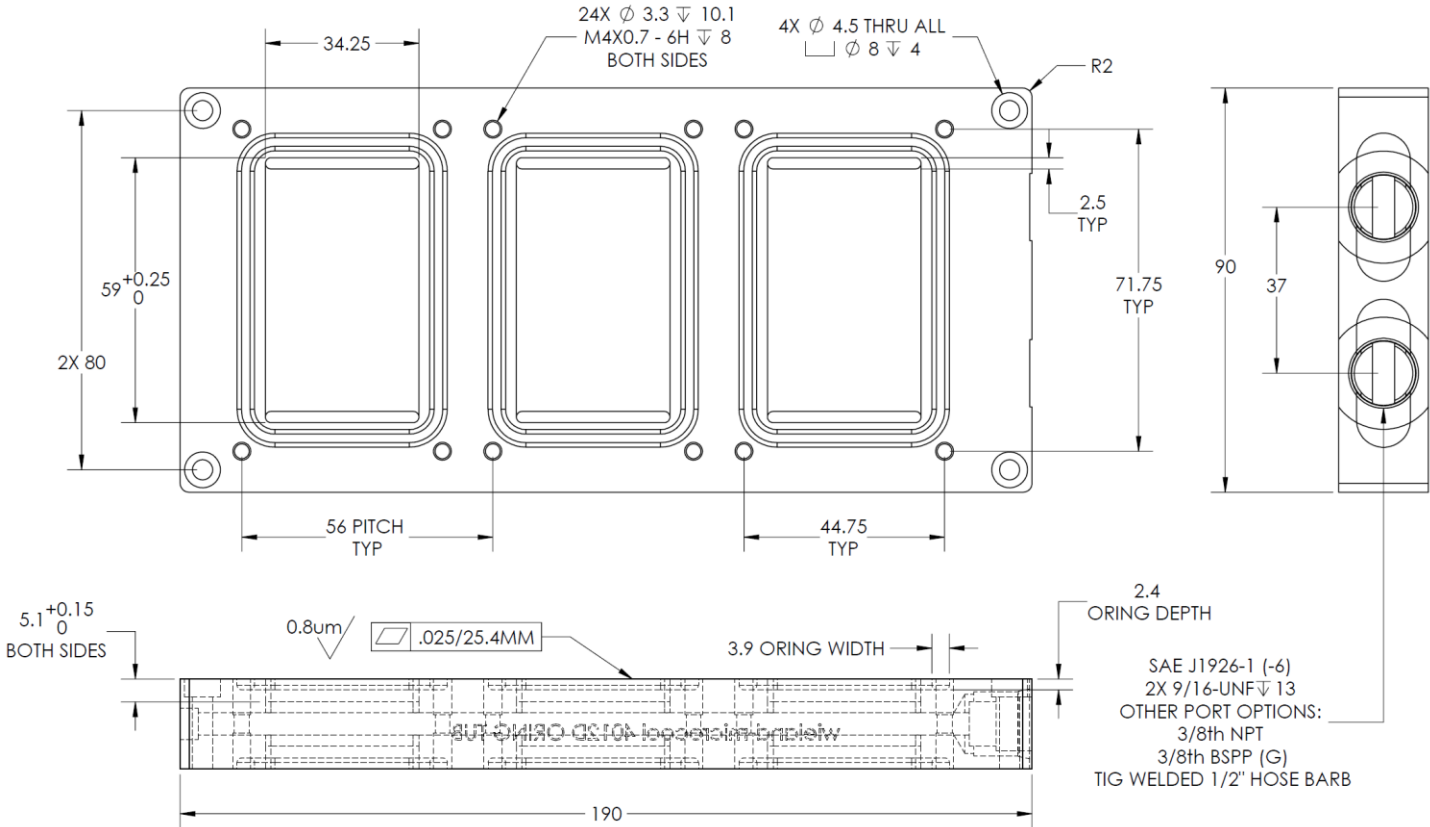

NOTES:

1. DIMENSIONS AND TOLERANCES IAW ASME Y14.5M - 1994
2. MATERIAL: ALUMINUM 6061-T6 OR 6063-T6 (TUB) / METRIC O-RING ISO 3601, BUNAN/NITRILE, SHORE 70^a (O-RING)
3. FINISHED ASSEMBLY MASS: 680 GRAMS

Custom Options (call or email):

- Length: Extrusion length can change to accommodate up to 8 IGBTs
- Ports: NPT/SAE/BSPP (G)/ Welded on hose barb
- Plating Options: Electroless Nickel inside and out available
- Double sided options